

# INSTALLATION OF ARTICULATING ARM

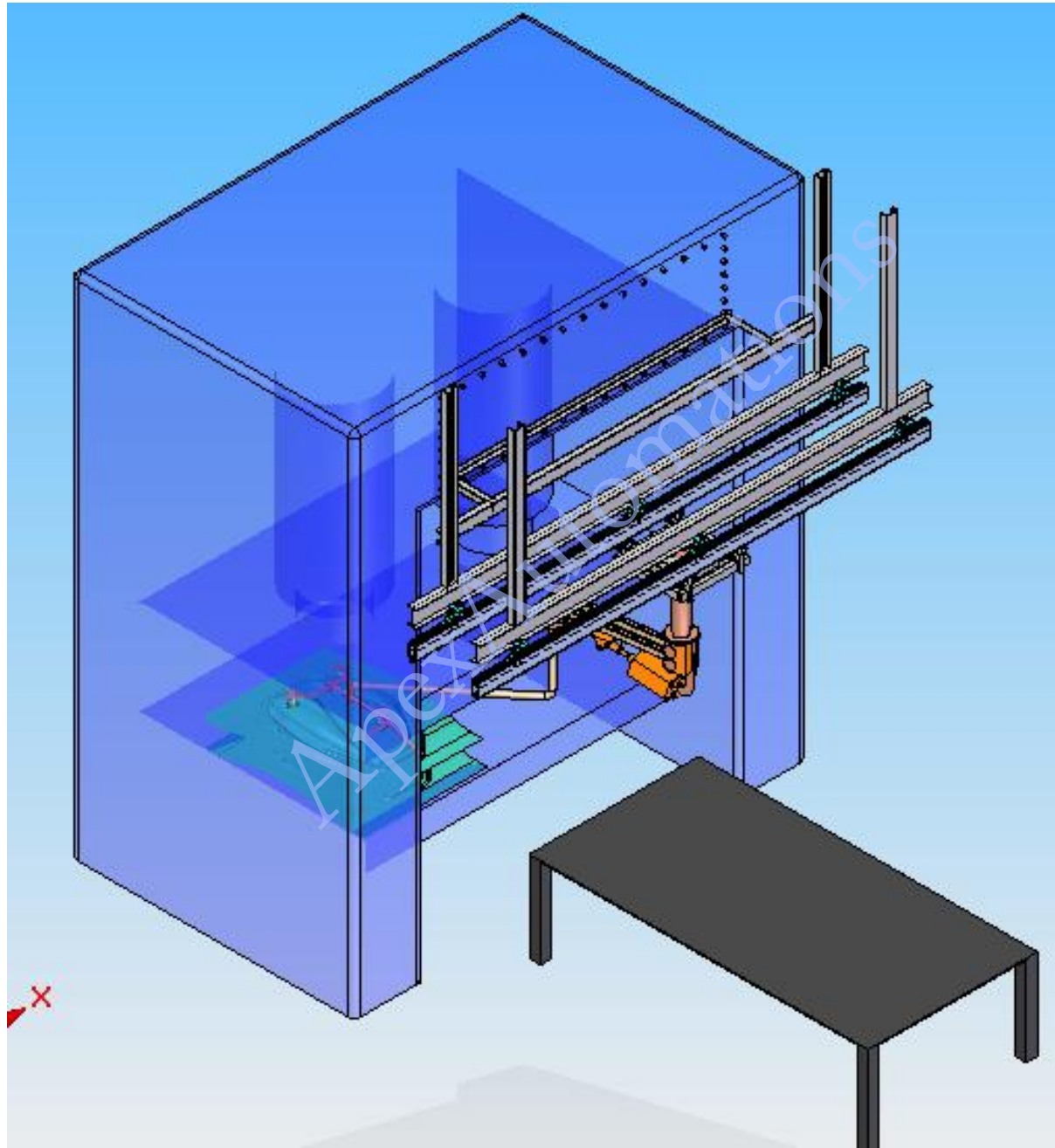

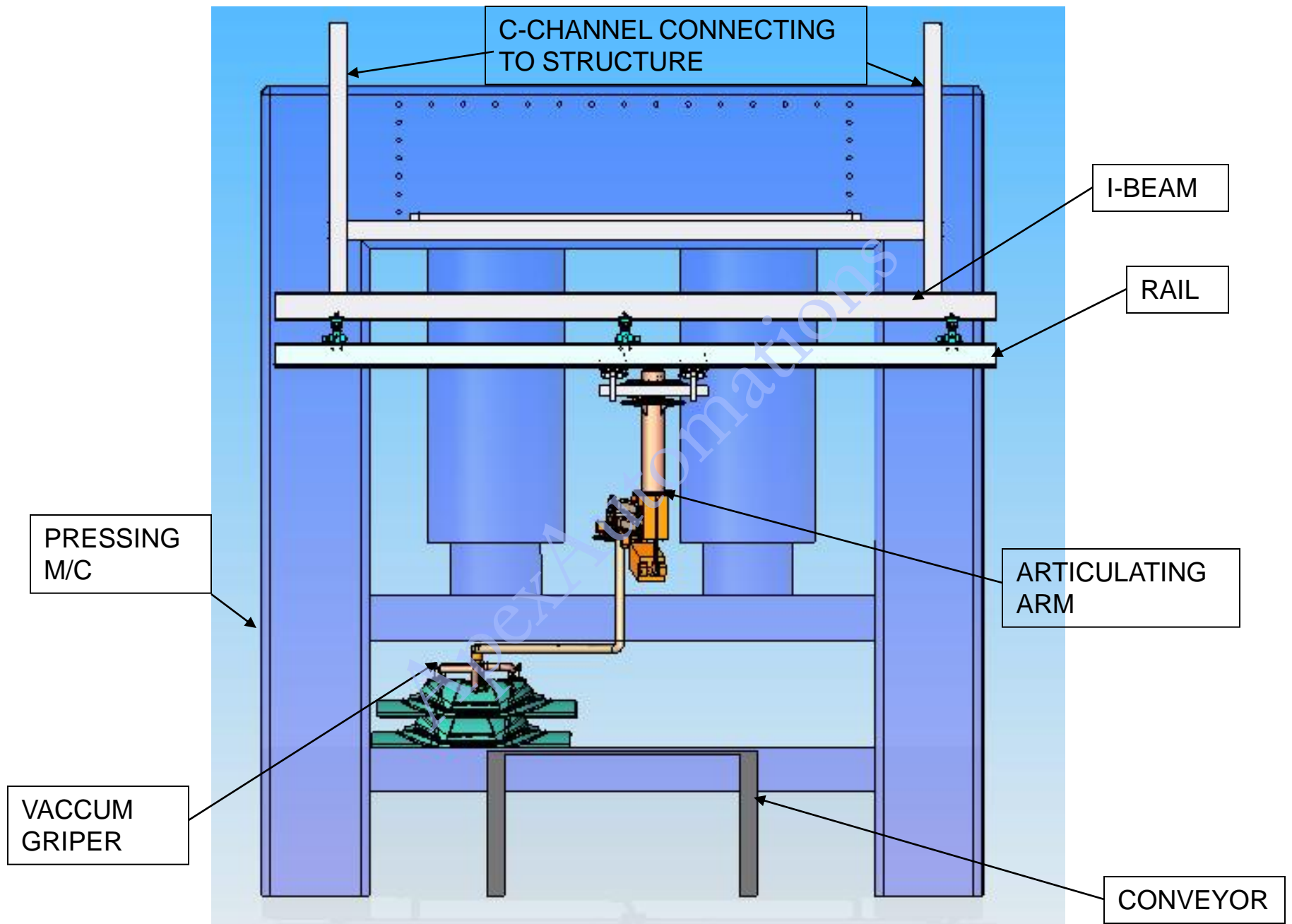

**Structure design is as per customer scope**

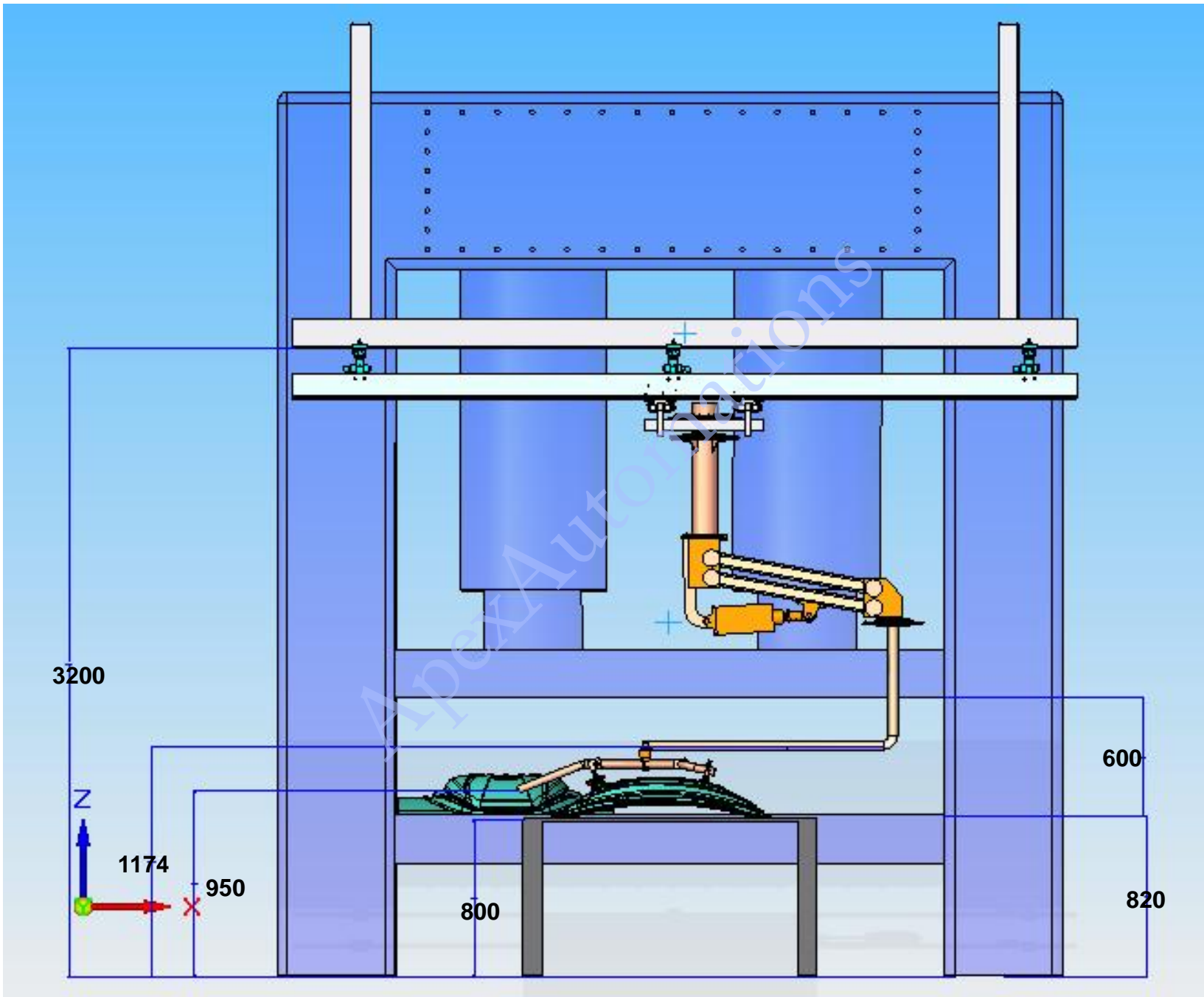

# VACCUM GRIPER MECHANISM

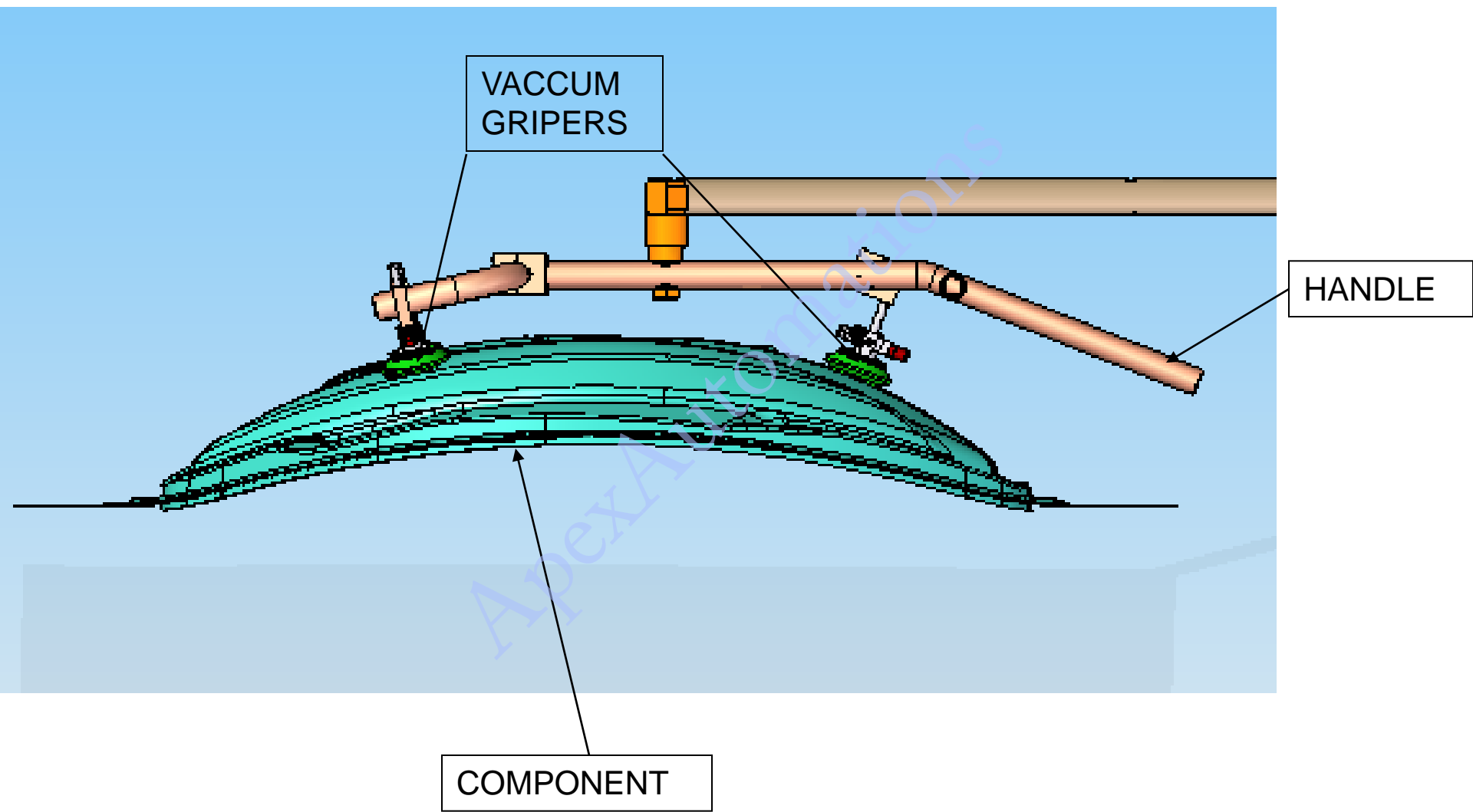

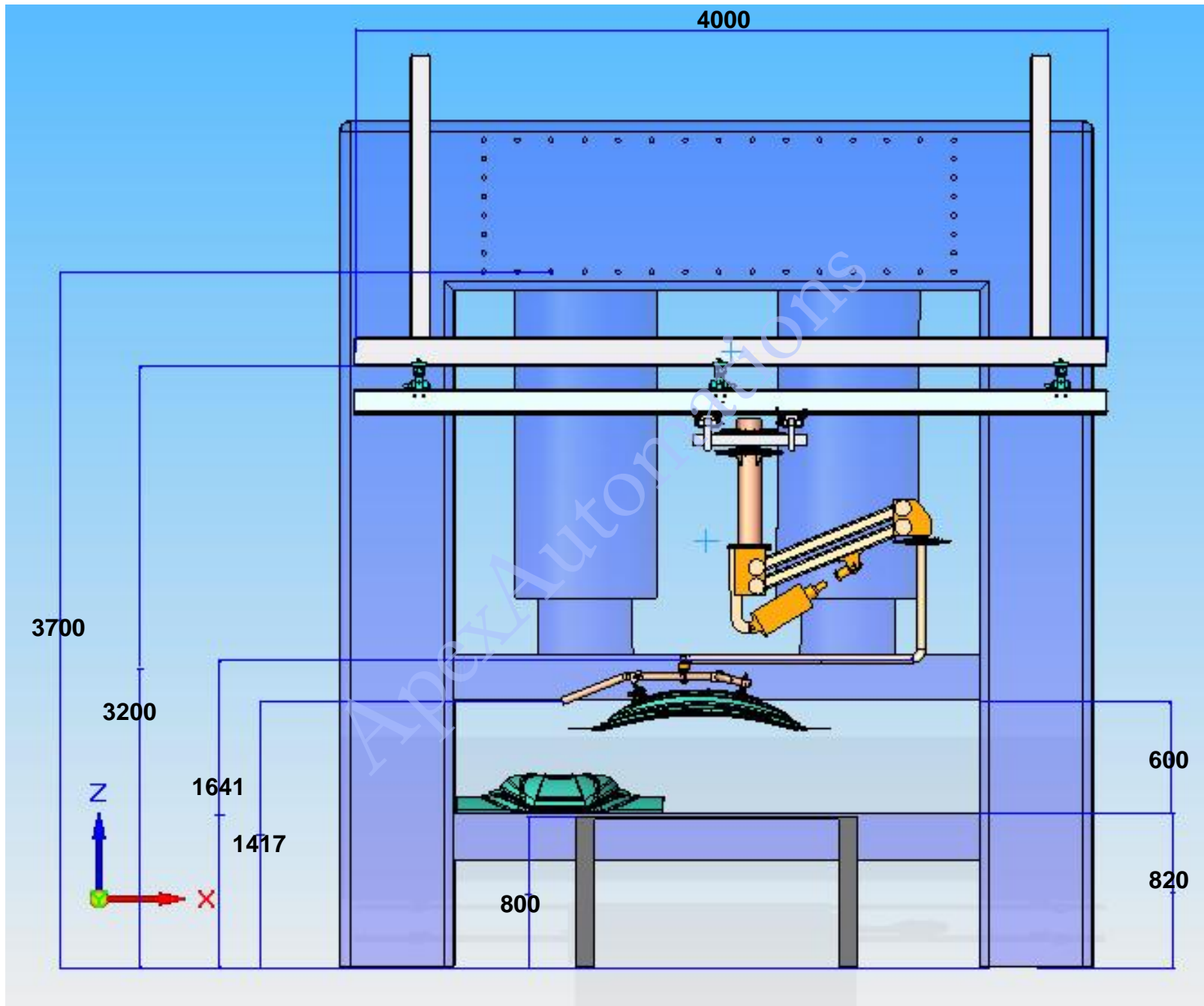

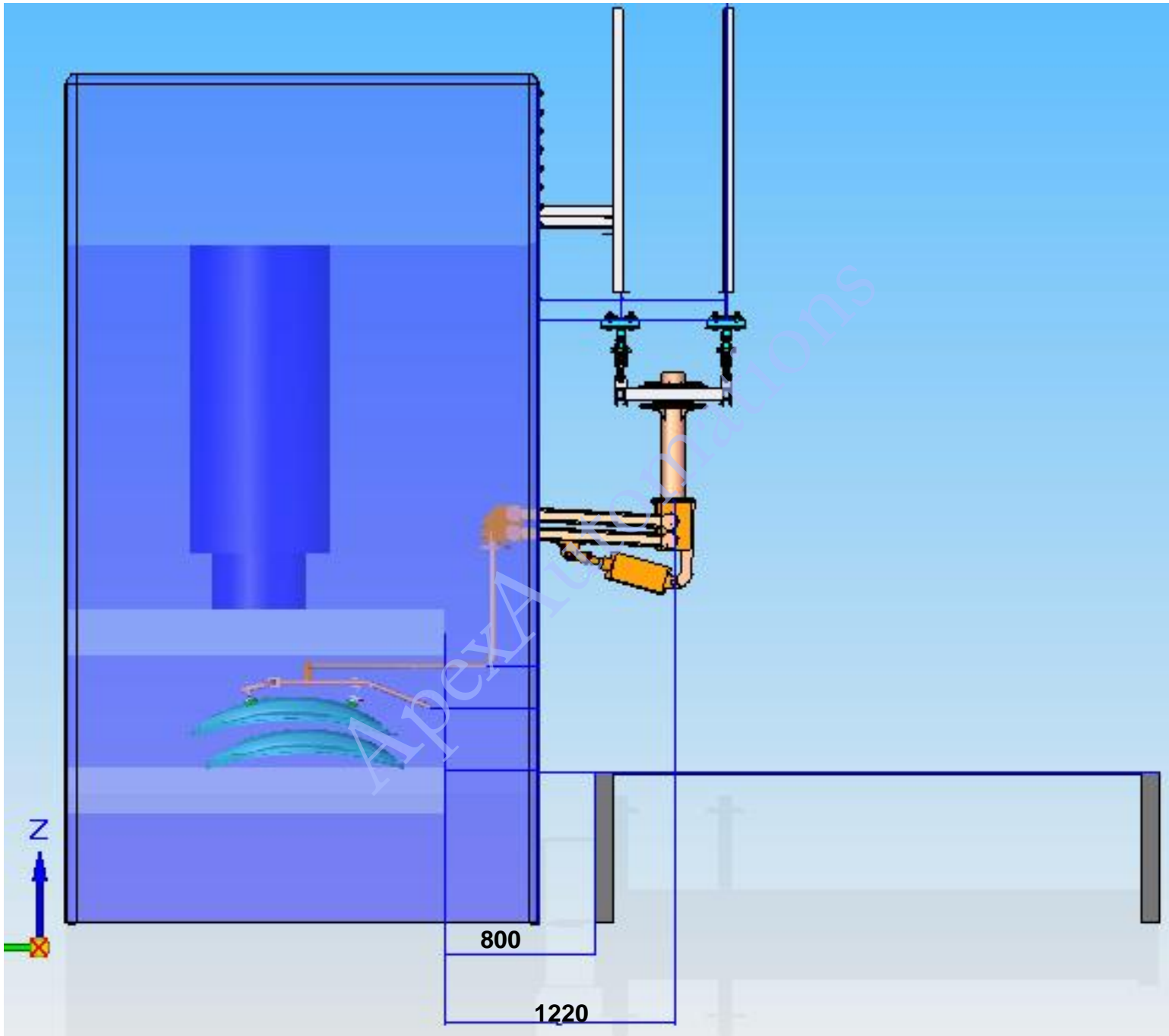

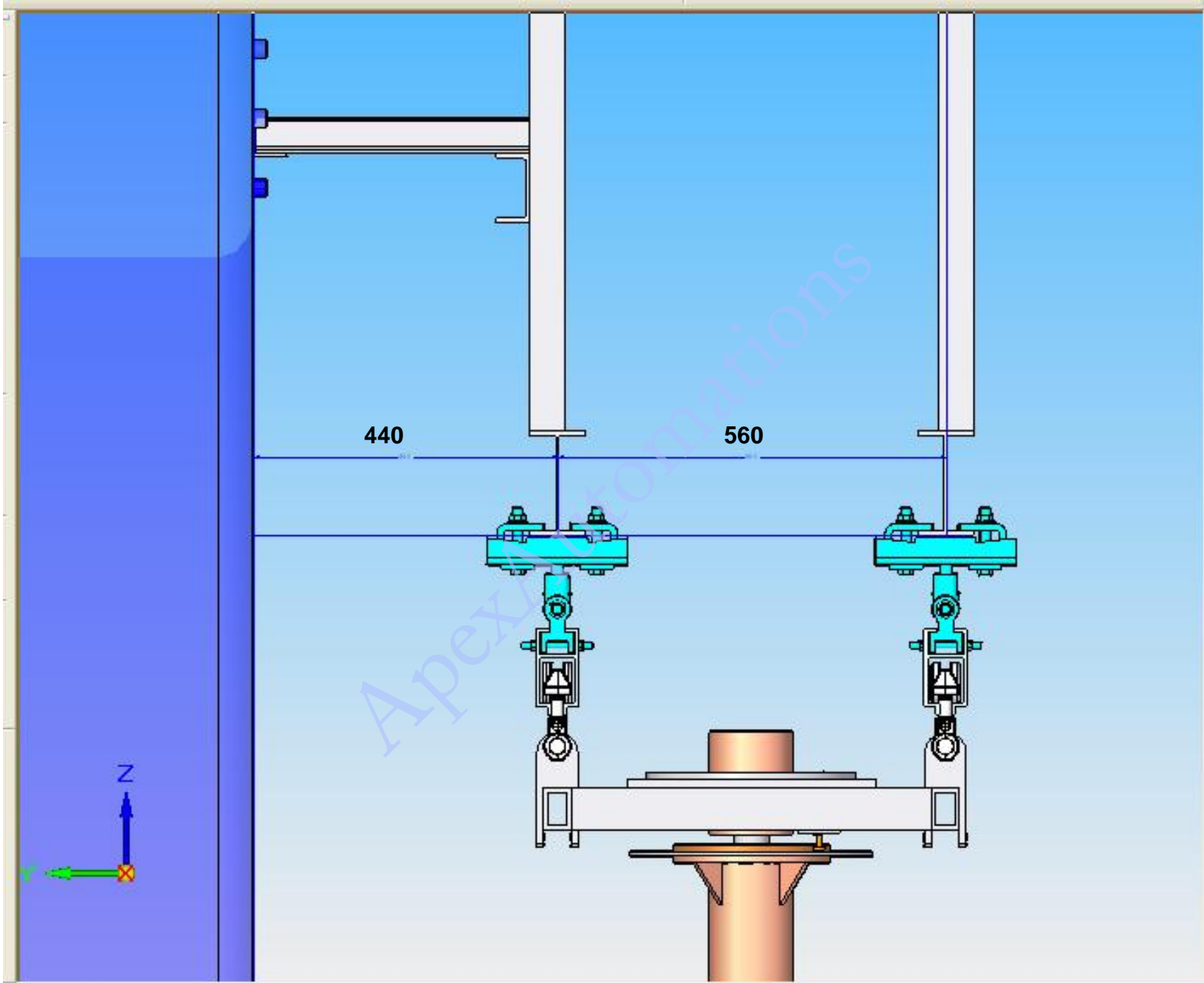

## Working area of the articulating arm.

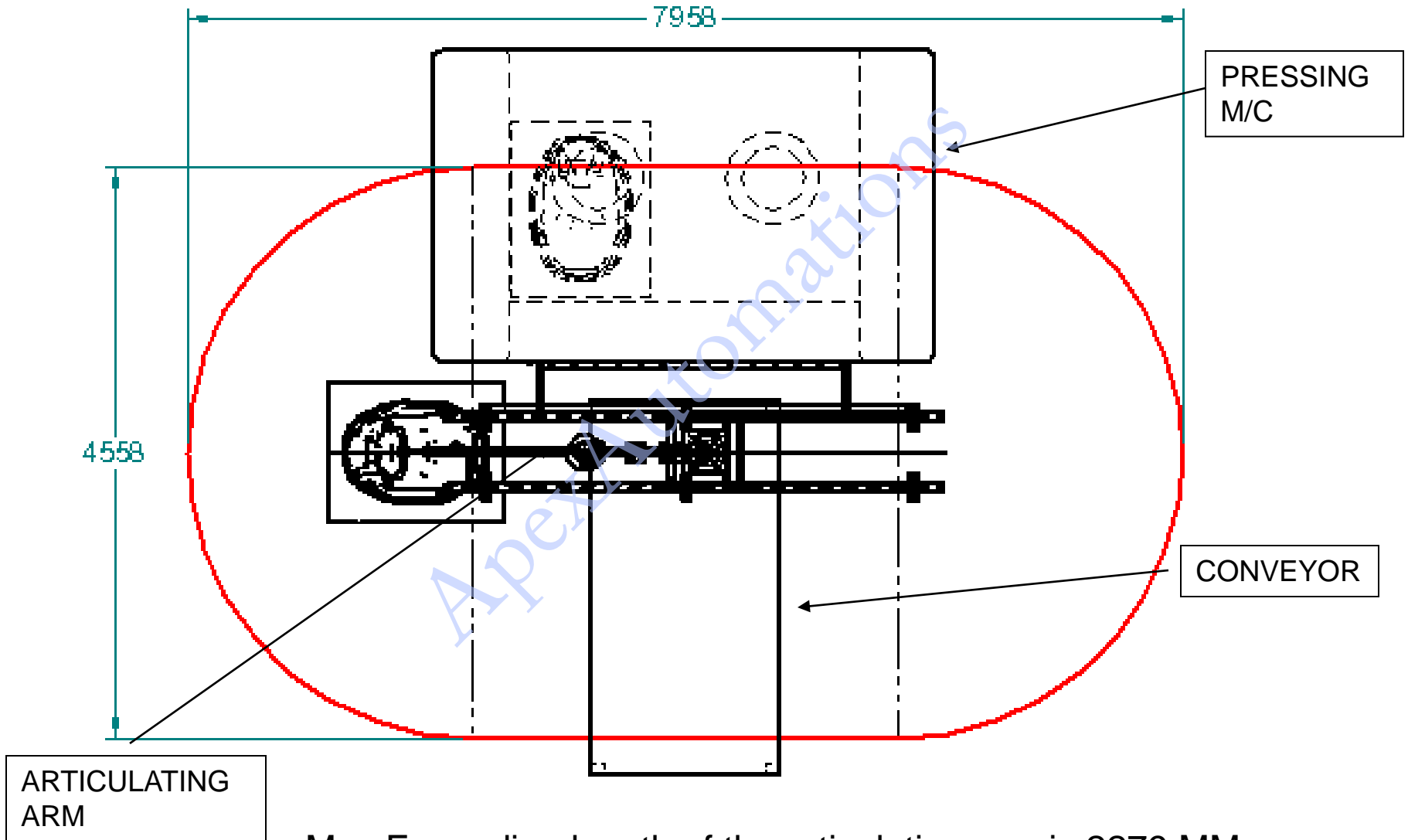

Max Expanding length of the articulating arm is 2279 MM